

HAL 39xy, HAC 39xy, and HAR 39xy

June/2024



HAL 39xy, HAC 39xy, and HAR 39xy Stray-Field Robust 3D Position Sensors Family with Different Output Formats

HAL 39xy is a new generation of 3D position sensors from TDK-Micronas addressing the need for stray-field robust position sensors (linear and angular) as well as the ISO 26262 compliant development.

This sensor family consists of various members. A detailed overview can be found on the back page.

All devices can measure a 360° angular range as well as linear movements. HAL/R 3900 and HAL/C/R 393x support the option for 3D position detection. Depending on the device, it is possible to transmit temperature-compensated values of B_x , B_y , B_z or up to two calculated angles. The HAL 3980 is also capable of transmitting the angular speed.

All devices offer setpoint linearization with either 33 equidistant distributed setpoints or 17 variable setpoints.

The sensors measure the position of a magnet based on 3D HAL® technology from TDK-Micronas. The devices are able to suppress external magnetic stray fields by using an array of Hall plates. Only a simple two-pole magnet is required to measure a rotation angle. Off-axis measurements are also possible.

The sensors are defined as SEooC (Safety Element out of Context) up to ASIL C ready according to ISO 26262.

Major characteristics like gain and offset, reference position, etc. can be adjusted to the magnetic circuitry by programming the non-volatile memory.

The devices are designed for operation in an ambient temperature range of -40 °C up to 150 °C.

The HAL 39xy devices are available in a very small eight-pin SOIC8 package.

The HAC 39xy devices are available in a three-pin leaded TO92UF package. This package integrates up to two capacitors (max. 330 nF) together with the sensor chip.

With the integrated capacitors, HAC 39xy meets stringent ESD (system level) and EMC requirements and eliminates the need for a PCB, thus reducing the total system size and cost.

The HAR 39xy devices are available in a small sixteen-pin SSOP16 package with full redundancy. Each sensor contains two independent dies placed upon each other that are mechanically separated and electrically insulated. The two dies measure almost the same magnetic field, therefore ensuring synchronous output signals.

Features

- ◆ Accurate angular measurement up to 360° and linear position detection
- ◆ 3D position detection (Stray-field robust)
- ◆ Robust against magnetic stray fields
- ◆ Up to ASIL-C ready (SEooC according to ISO 26262:2018)
- ◆ Wide supply voltage range: 3.0 V to 18 V
- ◆ Configurable output slew rates
- ◆ 0.1 kHz to 2 kHz PWM frequency
- ◆ Separate switch output (HAL 3930 / HAR 3930 / HAR 3920)
- ◆ Ratiometric analog output (HAR 3920)
- ◆ SENT according to SAE J 2716 rev. 4 support different frame formats
- ◆ SPC interface with ID selection mode, rolling counter, temperature information
- ◆ SPI interface (slave)
- ◆ Integrated low-power modes
- ◆ PSI5 interface according to rev. 2.3
- ◆ 2-wire PWM interface
- ◆ Read-in of external signal (PWM/Switch)
- ◆ $T_A = -40\text{ °C}$ up to 150 °C

HAL 39xy, HAC 39xy, and HAR 39xy

June/2024

Major Applications

HAL 39xy, HAC 39xy, and HAR 39xy are potential solutions for the following application examples:

- ◆ Chassis position
- ◆ Turbo-charger actuators
- ◆ Valve position detection
- ◆ EGR
- ◆ Shift position
- ◆ Steering angle
- ◆ Steering column switches
- ◆ Fuel-level measurements
- ◆ Clutch position
- ◆ Transmission position detection
- ◆ Brake stroke position sensors
- ◆ Accelerator pedal position detection

Development Tools

HAL 39xy, HAC 39xy, and HAR 39xy can be programmed during the final manufacturing process by adjusting the output signals directly to the input signal. With this calibration procedure, the tolerances of the sensor, the magnet, and the mechanical positioning can be compensated in the final assembly.

TDK-Micronas offers an easy-to-use evaluation kit for engineering:

- ◆ Micronas programmer board (TDK-MSP V1.x) for HAL/R/C 39xy
- ◆ USB programming kit for HAR 3920, HAL/R/C 393x and HAL/R 3970
- ◆ LabVIEW™ programming software for Windows®
- ◆ TDK SPI programmer for HAL/R 3900

License Note:

Some of HAL 39xy, HAC 39xy, and HAR 39xy use licenses of Fraunhofer Institute for Integrated Circuits

Available Types

Type	Output Format	Output Signals	ASIL Level	Other Features
HAL 3900-2300 HAR 3900-2300	SPI	Up to two angles or values of B_x , B_y , and B_z	ASIL-B	<ul style="list-style-type: none"> ◆ Low-power mode with wake-up by magnetic field / position information change / wake-up pin ◆ 16-bit data with CRC and rolling counter ◆ 5 MHz SPI
HAR 3920-210x	Analog/ Switch	One angle per die	ASIL-C	<ul style="list-style-type: none"> ◆ Passive wire break detection ◆ Programmable clamping-levels
HAL 3930-2300 HAC 3930-2300 HAR 3930-2300 HAL 3930-410x HAR 3930-410x	PWM/ SENT/ Switch	Up to two angles/each die	ASIL-B ASIL-B ASIL-B ASIL-C ASIL-C	<ul style="list-style-type: none"> ◆ Push-pull or open-drain output ◆ Programmable switching levels (HAL 3930 / HAC 3930 only)
HAL 3936-4100 HAR 3936-4100	PWM/ SENT/	Up to two angles/each die	ASIL-C ASIL-C	<ul style="list-style-type: none"> ◆ Read-in of external signals (PWM/Switch) and transmission via SENT ◆ Stray-field robust joystick mode
HAL 3960-2300	PWM	One angle	ASIL-B	<ul style="list-style-type: none"> ◆ 2-wire PWM
HAL 3970-230x HAR 3970-2301	SPC (Short PWM Code)	One angle and temperature	ASIL-B	<ul style="list-style-type: none"> ◆ Secure rolling counter ◆ Enhanced 12-bit serial message
HAL 3980-2300 HAC 3980-2300	PSI5 rev. 2.3	One angle and angular speed	ASIL-B ASIL-B	<ul style="list-style-type: none"> ◆ PSI5 rev. 2.3 and support of frames of rev. 1.3 ◆ Asynchronous mode, synchronous parallel and universal bus mode, variable time-triggered bus mode

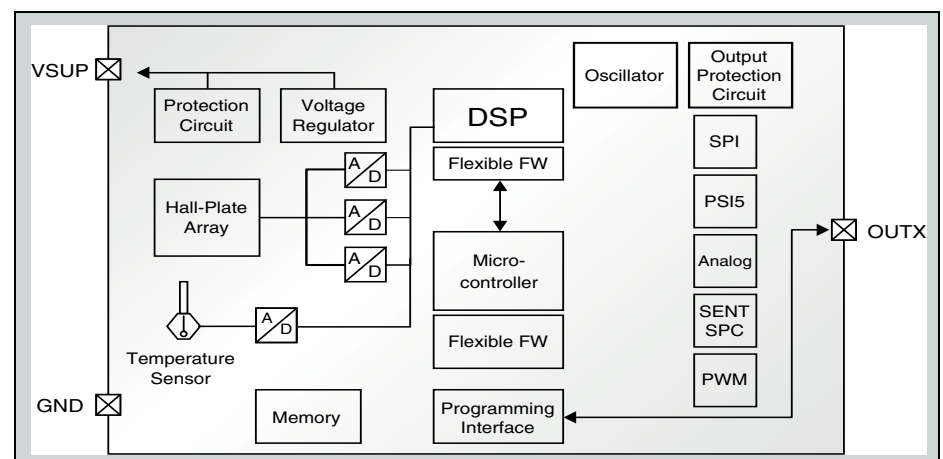

Fig. 1: Block diagram of the HAL 39xy

All information and data contained in this product information are without any commitment, are not to be considered as an offer for conclusion of a contract, nor shall they be construed as to create any liability. Product or development sample availability and delivery are exclusively subject to our respective order confirmation form. By this publication, TDK-Micronas GmbH does not assume responsibility for patent infringements or other rights of third parties which may result from its use.

No part of this publication may be reproduced, photocopied, stored on a retrieval system, or transmitted without the express written consent of TDK-Micronas GmbH.

Edition Jun. 04, 2024; Order No. PI000164_007EN